



Application for Public Hearing VARIANCE

YOU MUST PROVIDE THE FOLLOWING INFORMATION: IF ADDITIONAL SPACE IS NEEDED, ATTACH EXTRA PAGES TO THE PETITION.

Name of Business (if Applicable): BLUE SKY BUILDERS INC.

Address/Location of Property in Question: 1018 N. HARVEY AVE

Property Identification Number(s)(PIN): 16-05-115-004-0000

Name of Property Owner(s): CATHERINE BENDOWITZ

Address of Property Owner(s): 1018 N. HARVEY AVE

E-Mail of Property Owner(s): CBENDOWITZ@GMAIL.COM Phone: 312-953-5511

If Land Trust, name(s) of all beneficial owners: (A Certificate of Trust must be filed.) _____

Name of Applicant(s) (if different than Property Owner): BLUE SKY BUILDERS INC.

Applicant's Address: 424 OGDEN AV, DOWNERS GROVE IL 60515

Applicant's Contact Information: Phone 630-852-8485 E-Mail CUSTOMERSERVICE@BLUESKYBUILDERS.COM
Other: DAVE - 630-873-9840

Property Interest of Applicant: _____ Owner _____ Legal Representative _____ Contract Purchaser X Other

(If Other - Describe): CONTRACTOR FOR NEW GARAGE

Property Type: 1 or 2 Family Residential Multiple-Family Commercial Mixed-Use Hospital Institutional

Zoning District: R-1 R-2 R-3(50) R-3(35) R-4 R-5 R-6 R-7
 DT (1-2-3) GC HS MS NA NC RR
 H OS I

Describe Variance Proposal: REDUCED ALLEY SETBACK FROM 4' TO APPROX 2.5' TO ACCOMMODATE A STANDARD 2 CAR GARAGE (ARTICLE 9.3 A5C)

Size of Parcel (from Plat of Survey): 4557 SF Square Feet

Adjacent:	Zoning Districts	Land Uses
To the North:	_____	_____
To the South:	_____	_____
To the East:	_____	_____
To the West:	_____	_____

Is the property in question currently in violation of the Zoning Ordinance? ___ Yes X No
If Yes, how? _____

Is the property in question currently subject to any zoning relief? ___ Yes X No
If Yes, how? _____
If Yes, please provide relevant Ordinance No.'s _____

Is the subject property located within any Historic District? ___ Yes X No
If Yes: Frank Lloyd Wright Ridgeland/Oak Park Gunderson

From what Section(s) of the Zoning Ordinance are you requesting approval / relief?

Article: 9.3 A S C Section: _____
Article: _____ Section: _____
Article: _____ Section: _____

Explain why, in your opinion, the grant of this request will be in harmony with the neighborhood and not contrary to the intent and purpose of the Zoning Ordinance or Comprehensive Plan;
TO REPLACE A DILAPIDATED 1 CAR GARAGE WITH A STANDARD SIZED 20x20 2 CAR GARAGE TO STORE 2 VEHICLES ETC.

I (we) certify that all the above statements and the statements contained in any papers or plans submitted herewith are true to the best of my (our) knowledge and belief.

I (we) consent to the entry in or upon the premises described in this application by any authorized official of the Village of Oak Park for the purpose of securing information, posting, maintaining and removing such notices as may be required by law.

DAVID D KRECEK

(Printed Name) Applicant

David D. Krecek

(Signature) Applicant

4-1-2024

Date

(Printed Name) Owner

(Signature) Owner

Date

Owner's Signature must be notarized

SUBSCRIBED AND SWORN TO BEFORE ME THIS

_____ DAY OF _____, _____

(Notary Public)

APPLICATION CHECKLIST

Variation

Project Title: GARAGE REPLACEMENT

Project Address: 1018 N. HARVEY AV.

Application Guidelines:

This is a general checklist. Other items of information pertaining to your case may be deemed necessary by the Zoning Board of Appeals or its Liaison at any time during the processing or hearing of this case. Applications will not be accepted for processing until all of the submittal items are received by the Zoning Administrator.

- For questions regarding this checklist or the variation process, please contact:

Michael Bruce, Zoning Administrator at 708-358-5449 or by e-mail at bruce@oak-park.us

- To assist Applicants in preparation of their application, copies of application packets from previously heard variation cases are available for review at the Village Hall through the Zoning Administrator. Please contact Michael Bruce at 708-358-5449 or by e-mail at bruce@oak-park.us.
- All applications shall include at a minimum the items of information indicated within this checklist. The Applicant may request in writing a waiver of any application requirement. Such requests shall be directed to the Zoning Administrator for review and approval.
- All items of information, excluding the petition and fee, must be collated and bound together, hereinafter referred to as the application packet. Applicants may alternatively submit a complete application in electronic PDF format.
- Applicants are encouraged to attend a pre-filing meeting with the Zoning Administrator to review the contents of the application packet prior to submittal.
- The general application process and hearing timeline is established by the Zoning Administrator with the following guidelines. Please note that special conditions such as holidays or case load of the ZBA may affect your exact schedule.
 - Upon receipt of the completed application packets a meeting will be scheduled with the Project Review (PRT) team to review the proposed project and variation request. PRT meetings are generally held on the first and third Monday of each month. Feedback comments from that meeting will be forwarded in writing to the applicant for their information and use in preparing their case. Unless the team determines a need to review revised drawings the

- case will then be scheduled for a public hearing in front of the ZBA.
 - The ZBA generally hears cases on a first come, first served basis. The Zoning Administrator will inform the applicant of the next available hearing date.
 - Notice of public hearings on requests for variations, special uses or amendments are required to be published in a newspaper of general circulation in the village of Oak Park not more than thirty (30) days or less than fifteen (15) days before the hearing date. The Village will arrange for publication of the notice at no additional cost to the applicant.
 - Except in the case of request for map amendments, the Village shall also post a sign containing the information contained within the notice on the property which is the subject of the application, no less than fifteen days prior to the public hearing. The Village will remove the sign from the property once the hearing has been completed.
 - In the case of requests for a special use or map amendment, notice of the public hearing shall also be provided by the Applicant by registered mail to the owners of record of the property which is the subject of the application (if different than the applicant), and the owners of all property within five hundred feet of the Subject Property.
- The maximum sheet size for drawings or other submittal items shall be 11 inches by 17 inches. All drawings or other submittal items **must be folded** to approximately 8 ½" x 11". Drawings shall be of the following minimum scales:
 - ◆ Site Plans: one (1) inch equals fifty (50) feet
 - ◆ Building Plans: one (1) inch equals eight (8) feet
 - ◆ Building Elevations: one (1) inch equals eight (8) feet
 - Each drawing shall include the following basic information:
 - ◆ Project name and address
 - ◆ Drawing Title, Sheet Number if applicable, Date and latest revision date, if any
 - ◆ Exhibit Label
 - ◆ Scale, both in numerals and graphic
 - ◆ North arrow
 - ◆ Name of person(s) preparing the drawing along with address, telephone and facsimile number
 - ◆ Professional registration or affiliation if applicable, along with State of Illinois license number and Design Firm Registration number as applicable
 - ◆ Name, address and phone number of the property owner and/or applicant
 - **Application submittal items received less than (7) seven business days prior to the scheduled hearing date may not be accepted for review by the ZBA. Other items may be accepted at the discretion of the board.**

Please check if item is submitted or indicate N/A (Not Applicable)

— **1. APPLICATION FOR VARIANCE**

Attach the completed Application for Variation. The application must be notarized. A Notary Public is available at the Village Hall during normal

business hours. If the property owner's signature is not on the application, a letter stating the property owner's consent for the filing of the application is also required and shall be notarized.

— **2. COPY OF THE ZONING ADMINISTRATOR'S DECISION**

Attach a copy of the Zoning Officer's decision denying the Application for Building Permit based on the need for a zoning variation to construct the proposed project.

— **3. PROOF OF OWNERSHIP AND/OR PROPRIETARY INTEREST**

A current Deed, Title Policy, Long Term Lease, written Commitment to Purchase or written Option to Buy is required for proof of ownership and/or proprietary interest in the property.

— **4. DISCLOSURE OF BENEFICIARIES OF LAND TRUST**

Attach a completed Disclosure of Beneficiaries form. The Disclosure must be notarized. A Notary Public is available at the Village Hall during normal business hours.

— **5. PROJECT SUMMARY**

A written overview of the project and summary of evidence shall be submitted in the form of a cover letter that makes reference to plans and exhibits. In the event that an item in this Application Checklist does not apply, that fact should be clearly stated. The Applicant shall provide a description of the particular difficulties or hardships that occur if the strict letter of the Zoning Ordinance were applied, noting the difference between what could be built as of right and what is proposed to be constructed if the request for variation is granted.

— **6. RESPONSE TO APPROVAL STANDARDS**

A written response to each of the following standards that must be met in order for a variation to be granted (14.3 E of the Village of Oak Park Zoning Ordinance) must be submitted. Each standard must be quoted from the Zoning Ordinance and then followed by a reasoned response to the standard. Please note that all three standards must be met in order for the ZBA to grant any variance.

- a. The strict application of the terms of the Ordinance will result in undue hardship unless the specific relief requested is granted.
- b. The particular physical surroundings, shape or topographical conditions of the specific property impose a particular hardship upon the owner, as distinguished from a mere inconvenience, if the strict letter of the regulations were to be carried out.
- c. The plight of the owner is due to unique circumstances inherent to the subject property and not from the personal situation of the owner and has not been created by any person presently having a proprietary interest in the property in question.

Attach a copy of a Plat of Survey of the subject property prepared, signed and sealed by an Illinois Licensed Surveyor that accurately represents the state of the property at time of application.

8. LOCATION MAP

The minimum scale of location map shall be one (1) inch equals two hundred (200) feet. The location map should clearly indicate the property in question and the adjacent properties including zoning districts and buildings within 250 feet of the site. Copies of Sidwell or Sanborn maps or aerial photographs (any of which are available at no cost from the Village of Oak Park) are acceptable alternates to a drawn location map. Dimensions between the building(s) or structure(s) subject to the requested variance and all buildings or structures within 50 feet thereof shall be indicated on the location map.

9. SITE PLAN

A site plan of minimum scale of one (1) inch equals fifty (50) feet indicating the arrangement and tentative location and setbacks of all proposed uses, including buildings, structures, parking, driveways and other paved surfaces, fences and other surface features required to describe the project. The Site Plan shall include these same items on adjacent properties if such features are within 50 feet of the area subject to the variance request. The area affected by the request for variation shall be indicated on the plan.

10. FLOOR PLANS/ELEVATIONS

- Drawings of all floor levels of the existing building(s) and/or structure(s) highlighted to indicate the area(s) subject to the requested variation.
- Drawings of all floor levels of the building(s) and/or structure(s) indicating what could be constructed if the proposed project were built fully compliant with the Village of Oak Park Zoning Ordinance.
- Drawings of all floor levels of the building(s) and/or structure(s) highlighting the proposed construction if the zoning variation were to be granted.
- The drawings shall include a schedule showing the individual and total floor areas, new and existing, of the project.

11. PHOTOGRAPHS OF SURROUNDING PROPERTIES AND BUILDINGS

Photographs of buildings and structures shall be submitted as follows:

- View of existing building(s) and/or structure(s) marked to indicate areas to which the requested variation will apply.
- View from subject property in each compass direction indicating elevations of all adjacent buildings and/or structures.
- Views indicating relationship between subject property and any property(s) immediately adjacent to the area subject to the requested

variation.

- All photographs shall be labeled to indicate property/building street address and compass direction of view.

12. OTHER SUBMITTAL ITEMS

The Applicant may attach additional information as deemed necessary to fully describe or state their case. Items that the applicant should consider, but are not mandatory for submittal include:

- Architectural drawings, renderings or perspective drawings of all elevations of any existing building(s) and/or structure(s) subject to the requested variation.
- Architectural renderings or perspective drawings indicating the proposed project scope of work with the areas subject to the requested variation highlighted.
- Appraisal Letter
- Letter of opinion from a Real Estate Broker
- Profit/Loss Statement
- Developer's Pro-forma Budget
- Real Estate Market Study
- Leasing Report
- Letters of support from surrounding property owners

List other items deemed necessary by staff or Applicant to describe project or need for zoning variance.

For additional information regarding zoning regulations in the Village of Oak Park please refer to the Village of Oak Park Zoning Ordinance adopted September 18, 2017.

If after reviewing this checklist you have additional questions about the variation process please contact: Michael Bruce, Zoning Administrator at 708-358-5449 or by e-mail at bruce@oak-park.us.

IMPORTANT NOTE: THE VILLAGE OF OAK PARK STRONGLY RECOMMENDS THAT ALL APPLICANTS MEET WITH SURROUNDING RESIDENTS/PROPERTY/BUSINESS OWNERS ADJACENT TO ANY PROPOSED DEVELOPMENT **PRIOR TO** APPEARING BEFORE THE OAK PARK ZONING BOARD OF APPEALS.

RESPONSE TO APPROVAL STANDARDS

A written response to each of the following standards that must be met in order for a variation to be granted (14.3 E of the Village of Oak Park Zoning Ordinance) must be submitted. Each standard must be quoted from the Zoning Ordinance and then followed by a reasoned response to the standard. Please note that all three standards must be met in order for the ZBA to grant any variance;

- The strict application of the terms of this Ordinance will result in undue hardship unless the specific relief requested is granted. DUE TO TRAPEZOID LOT
- The particular physical surroundings, shape or topographical conditions of the specific property impose a particular hardship upon the owner, as distinguished from a mere inconvenience, if the strict letter of the regulations were to be carried out. TRAPEZOID LOT
- The plight of the owner is due to unique circumstances inherent to the subject property and not from the personal situation of the owner and has not been created by any person presently having a proprietary interest in the property in question. NOT CREATED BY OWNER.

RESPONSE TO APPROVAL STANDARDS: Bendowitz/Gilmour 1018 N Harvey

A written response to each of the following standards that must be met in order for a variation to be granted (14.3 E of the Village of Oak Park Zoning Ordinance) must be submitted. Each standard must be quoted from the Zoning Ordinance and then followed by a reasoned response to the standard. Please note that all three standards must be met in order for the ZBA to grant any variance;

- ✚ The strict application of the terms of this Ordinance will result in undue hardship unless the specific relief requested is granted. *Due to the alley being diagonal, it is physically impossible to build a standard sized 2 car garage 20x20 on the lot without the reduced alley setback requested creating a hardship for the resident to not be able to park 2 cars inside a garage.*
- ✚ The particular physical surroundings, shape or topographical conditions of the specific property impose a particular hardship upon the owner, as distinguished from a mere inconvenience, if the strict letter of the regulations were to be carried out. *As stated above, due to the alley being diagonal the variance is necessary vs a mere inconvenience.*
- ✚ The plight of the owner is due to unique circumstances inherent to the subject property and not from the personal situation of the owner and has not been created by any person presently having a proprietary interest in the property in question. *This is not a self created hardship. It was created when Ridgeland Ave and nearby blocks were developed with the bend in Ridgeland due to the continental divide.*

PLAT OF SURVEY

OF LOT 146 IN BON AIR, BEING A SUBDIVISION OF THAT PART OF THE NORTHWEST 1/4 OF SECTION 5, TOWNSHIP 39 NORTH, RANGE 13 EAST OF THE THIRD PRINCIPAL MERIDIAN, LYING SOUTH OF THE SOUTH LINE OF THE NORTH 75 ACRES THERETO, AND WEST OF A LINE 631.34 FEET WEST OF THE EAST LINE OF SAID 1/4 SECTION; NORTH OF THE NORTH LINE OF THE SOUTH 1/2 OF THE SOUTH 85 ACRES OF SAID 1/4 SECTION EAST OF THE CENTER LINE OF RIDGELAND AVENUE, IN COOK COUNTY, ILLINOIS.

ADDRESS: 1018 N. HARVEY, OAK PARK, ILLINOIS.



SCALE: 1"=15'

**PROPOSED
SITE PLAN**

20x20 GARAGE

N. HARVEY AVENUE
(66 FT. R.O.W.)
CURB

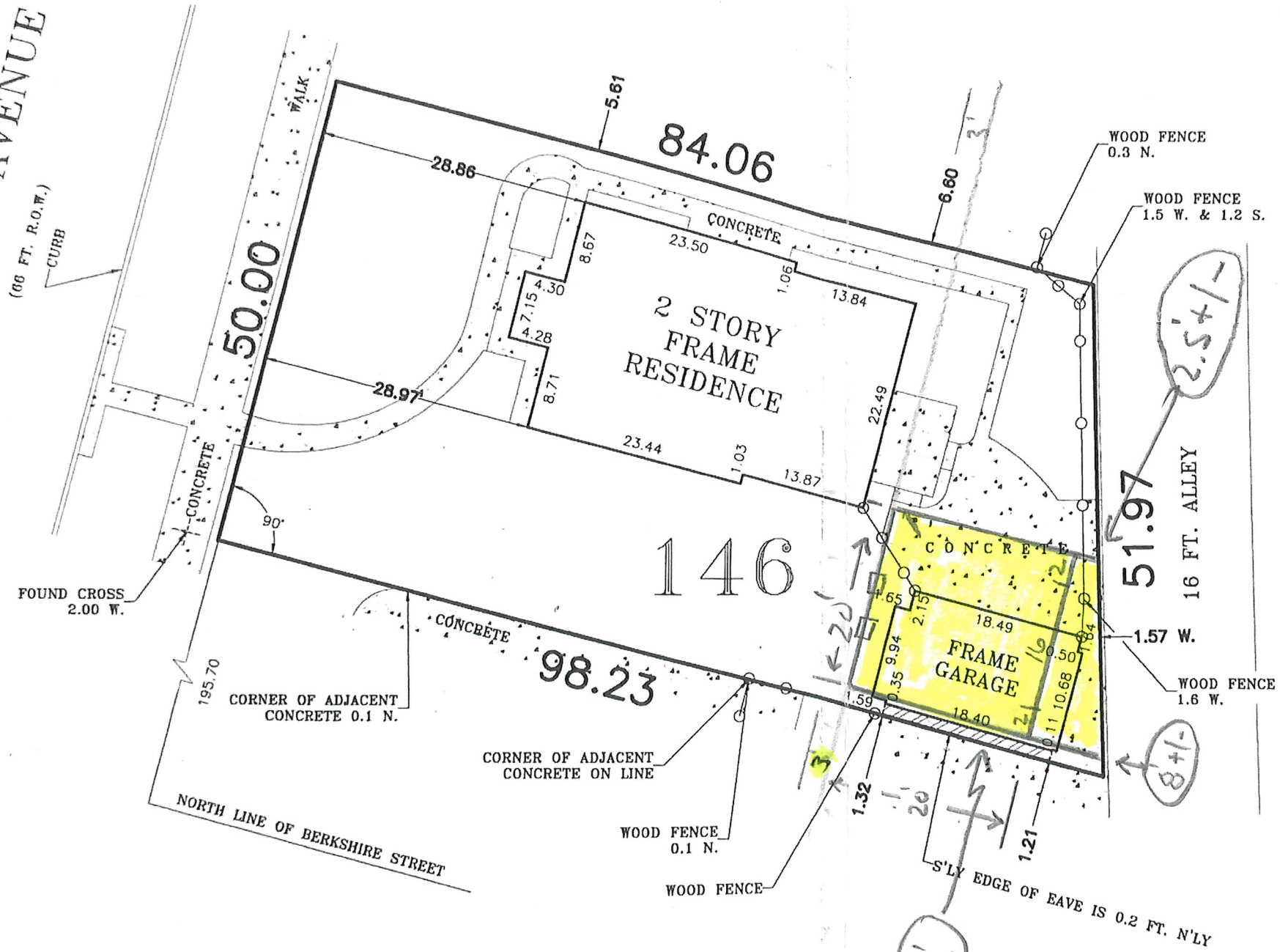

CONTACT INFORMATION:
TEL: (630) 852-8485
FAX: (630) 852-0350
424 OGDEN AVE
DOWNERS GROVE, IL 60515
CUSTOMER SERVICE@BLUESKYBUILDERS.COM

D. Kuen
3-2-2024

TO: BRIAN J. O'HARA

THIS IS TO CERTIFY THAT WE, PREFERRED SURVEY, INC., ILLINOIS PROFESSIONAL LAND SURVEYOR CORPORATION NO. 116 HAVE SURVEYED THE PROPERTY DESCRIBED HEREON AND THAT THE PLAT SHOWN HEREON IS A CORRECT REPRESENTATION OF THAT SURVEY, ALL DIMENSIONS SHOWN HEREON ARE IN FEET AND DECIMALS THEREOF. THIS PROFESSIONAL SERVICE CONFORMS TO THE CURRENT ILLINOIS MINIMUM STANDARDS FOR A BOUNDARY SURVEY. PROPERTY CORNERS ARE SET OR NOT BY CLIENT AGREEMENT. MY LICENSE RENEWS ON NOVEMBER 30, 2006. GIVEN UNDER OUR HAND AND SEAL AT BRIDGEVIEW, ILLINOIS, THIS 4TH DAY OF APRIL 2005



LAND AREA SURVEYED = 4557.3 Sq. Ft.



PREFERRED SURVEY, INC.

7845 W. 79TH STREET, BRIDGEVIEW, IL, 60455
Phone 708-458-7845 / Fax 708-458-7855

ILLINOIS PROFESSIONAL LAND SURVEYOR CORPORATION #116

P.S.I. NO. 0557803 FLD CREW HH/GS
CAD MO

424 Ogden Avenue
Downers Grove, IL 60515
630-852-8485
630-852-0350 fax

FOR: Andrew Gilmour
1018 N Harvey Ave
Oak Park

Date: 3/11/24

Scale: 1/8" = 1'

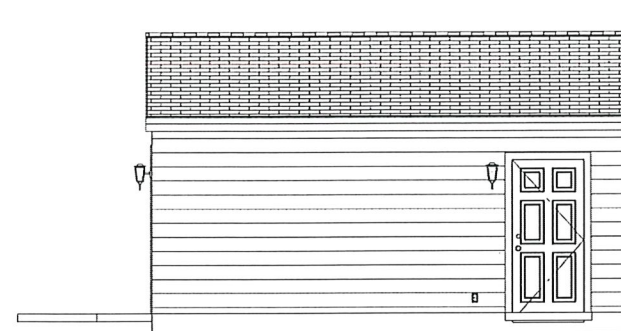
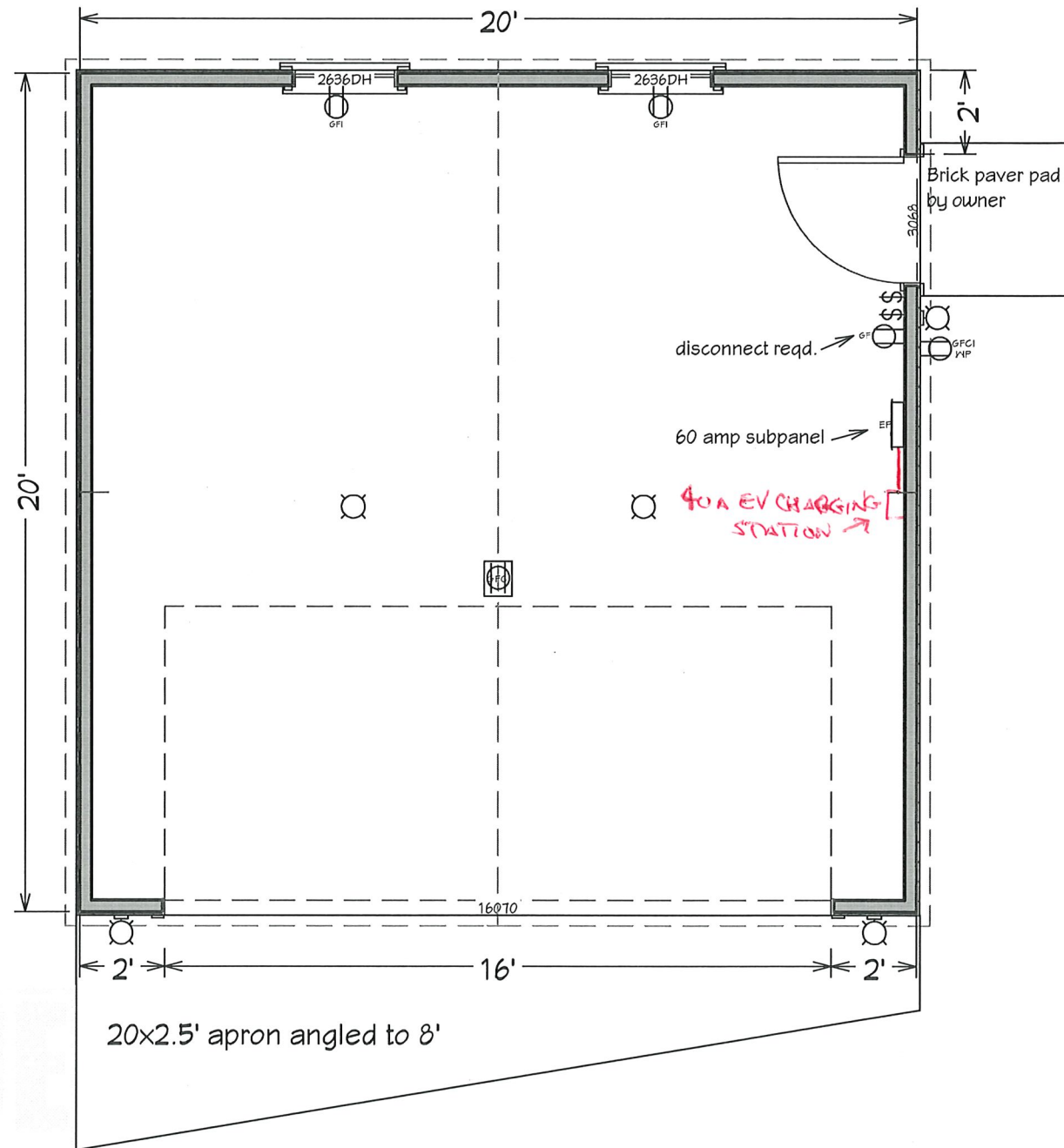

20' North Elevation Side

12'
8'

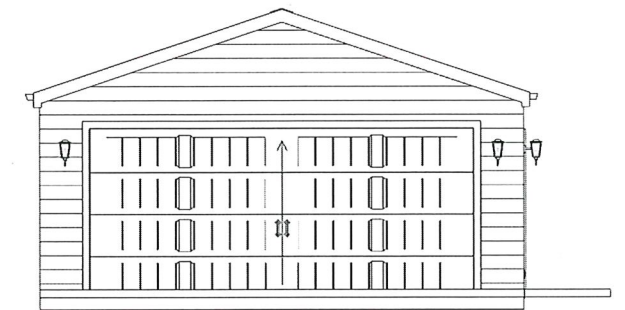

20' East Elevation Front

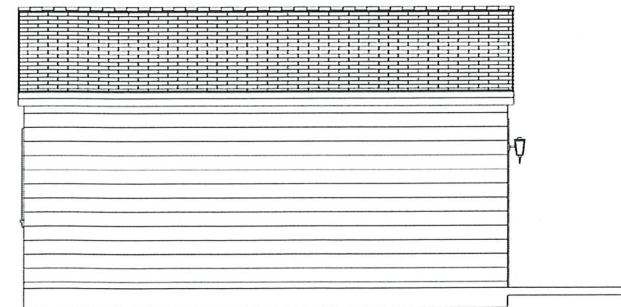

20' South Elevation Side

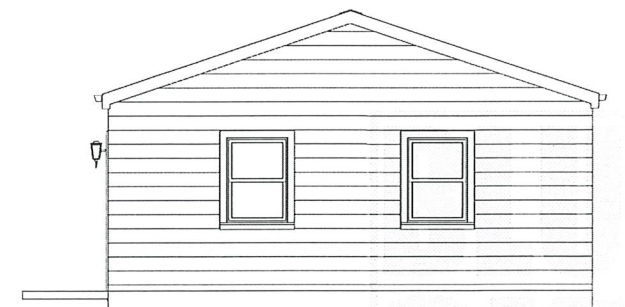

20' West Elevation Back

South wall, eave, and anything within 3' of lot line to be 1 hr fire rated w/ 5/8" gyp board

West wall, eave, and anything within 3' of lot line to be 1 hr fire rated w/ 5/8" gyp board

- GARAGE SIZE:** 20x20
- ROOF STYLE:** Gable
- WALL SHEATHING:** 4x8x7/16" OSB
- SWAY BRACES:** 4x8x7/16" OSB
- SIDING:** L.P. smartside w/ housewrap
- STUDS:** 2X4X16" O.C. w/ wolmanized plates SPF #2 OR BETTER
- TOP PLATE:** DOUBLE 2X4
- BOTTOM PLATE:** TREATED 2X4
- RAFTERS:** 2X6X16" O.C. w/ hurricane straps
- RIDGE:** 2X8 SPF #2 OR BETTER
- CROSS TIES:** 2X8X32" O.C.
- ROOFING:** 15# FELT UNDER 240# ASPHALT SHINGLE
- SHEATHING:** 4X8X1/2" OSB SPAN RATES 32/16 OR BETTER
- VENTS:** 2 mushroom
- EAVES:** 4" aluminum
- OVERHEAD DOOR:** 16x7 steel
- SERVICE DOOR:** 36" X 80"
- WINDOWS:** vinyl
- HEADERS:** —
O.H.D.: Cont. Double 1 3/4" x 11 7/8" MICROLAM LVL header
- SERVICE/WINDOW:** DOUBLE 2X8
- WALL HGT:** 8'
- TOTAL HGT:** 12'
- GUTTERS:** Yes - aluminum
- ANCHORS:** 1/2" ANCHOR BOLTS 4' O.C. AND 1' MAX / 6" MIN FROM CORNERS AND SPLICES IN PLATES - MIN 2 PER PLATE
- FLOOR:** 4" CONCRETE - 6 BAG MIX W/ #10 wire mesh & vapor barrier on 4" compacted sub-base
- APRON:** 6" CONCRETE ON 6" COMPACTED SUB-BASE
- WATER LEDGE:** RAISED CONCRETE ON 3 SIDES
- FOOTINGS:** 12x14 below grade w/ rebar 6" above grade

"All lumber SPF #2 or better unless otherwise noted"

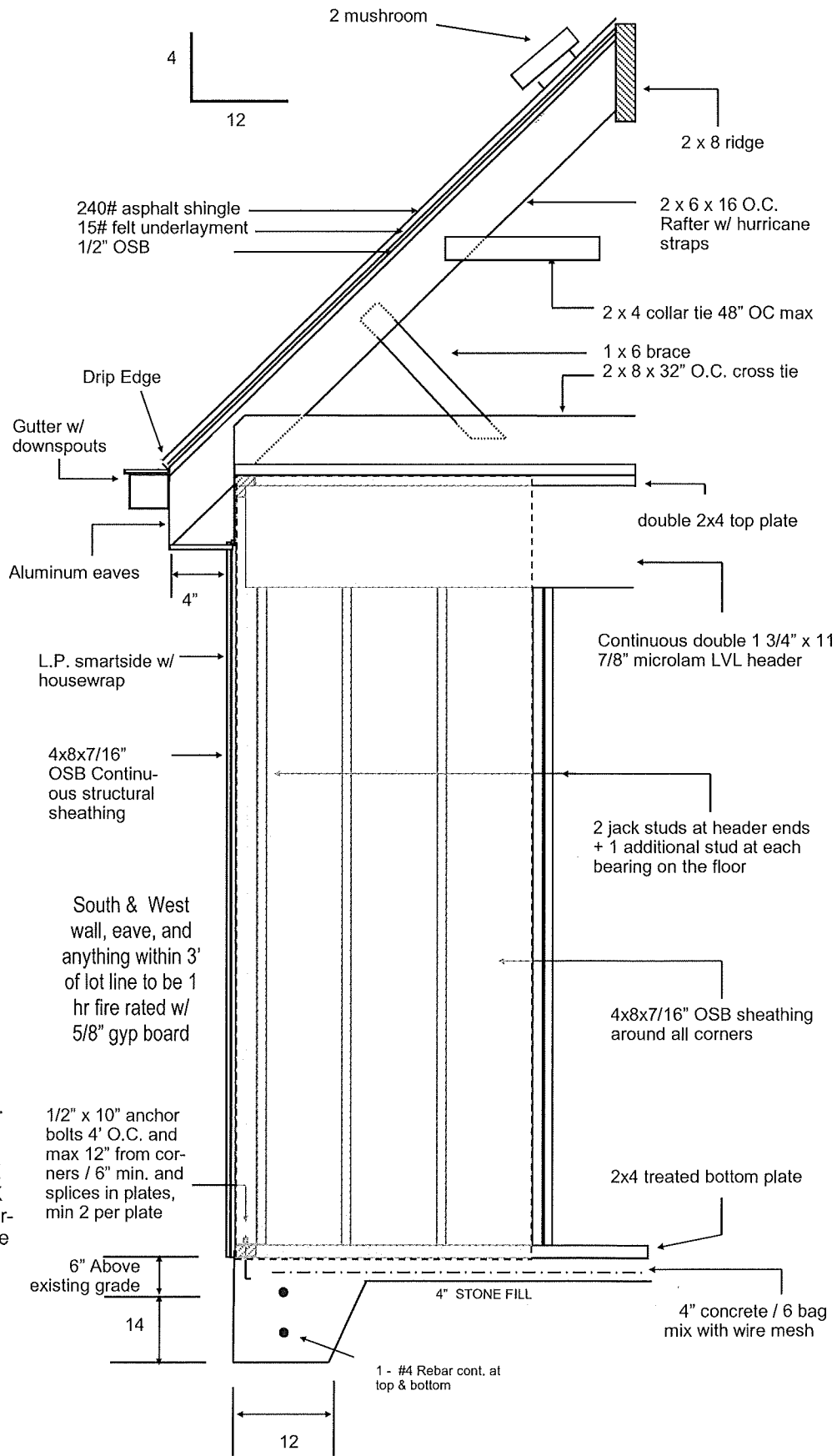

BLUE SKY BUILDERS
 424 OGDEN AVENUE
 DOWNERS GROVE, IL 60515
 630-852-8485
 630-852-0350 FAX

DATE: 3/11/24
SCALE: Not to Scale
SIZE: 20x20
ROOF: Gable
COST: \$44,465

FOR: Andrew Gilmour
 1018 N Harvey Ave
 Oak Park

Front Elevation

Method PFG (Portal Frame at Garage Door Openings)

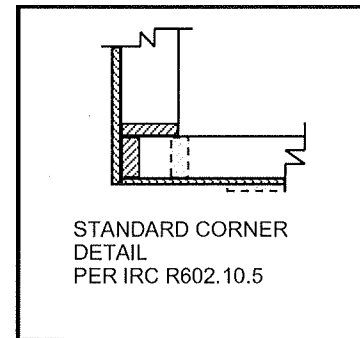
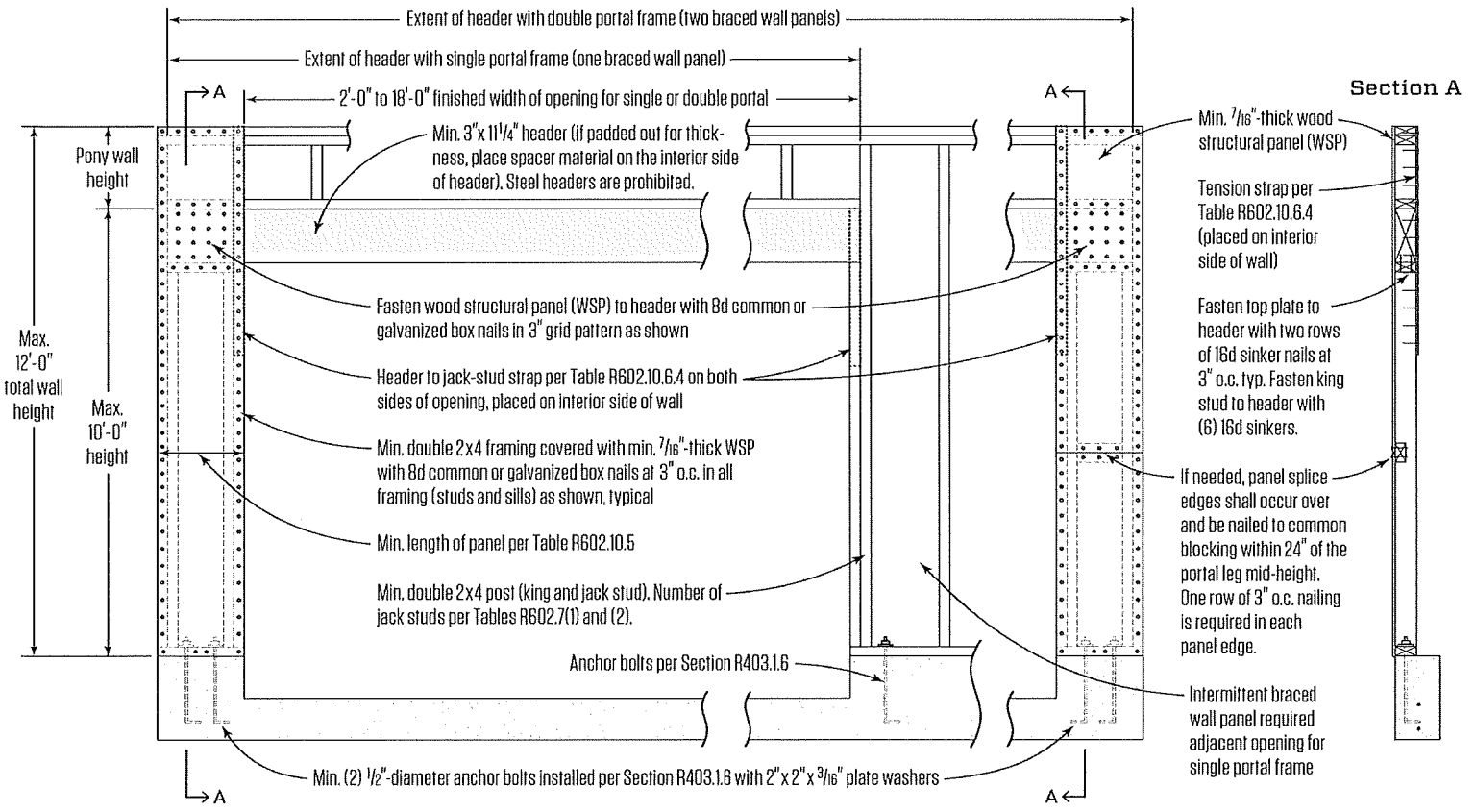

Typical B.S.B. Double Micro-Lam O.H.D.

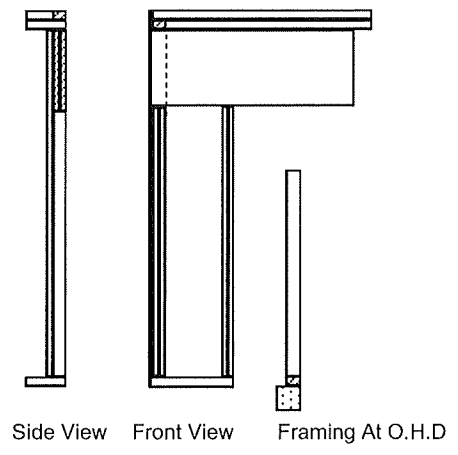

Typical B.S.B. Window Framing Layout

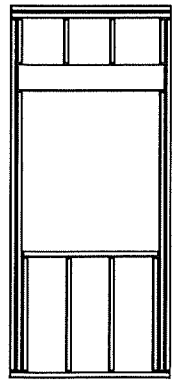

Additional Electric Info:

- 20 amp, #12 conductor THWN wire in raceway, 1/2" IMC conduit, 12" below grade min depth, w/ 20 amp circuit, all devices to be self grounding.
- All outlets to be tamperproof outlets.
- GARAGE DISCONNECT REQUIRED - To be located at first point of entrance inside garage.
- Distance between electric service panel and garage is less than 79'
- Any metal/rebar in concrete will be bonded to electrical system as required.

Address numbers to be posted on alley side

Cuts, notches, and holes bored in laminated lumber are not permitted unless the effects of such are specifically addressed by a registered design professional.

2018 International Residential Code (IRC) w/ Amendments
 2017 National Electrical Code (NEC) w/Amendments
 2018 Illinois Energy Conservation Code (IECC)
 Illinois State Plumbing Code with no Amendments
 2018 International Existing Building Code

Garage floor to be sloped toward the main vehicle entry.

ADDRESS: 1018 N Harvey Ave Oak Park, IL 60302

